



CLASS 10000 FANS OWNER'S MANUAL

CONTENTS

- 1.0 CLASS 10000 FANS OWNER'S MANUAL**
 - 1.2 INSPECTION**
- 2.0 INSTALLATION**
 - 2.2 INSTALL MANUAL HUB AND AIR SEAL**
 - 2.3 AUTOMATIC HUB AND AIR SEAL**
 - 2.4 INSTALL PNEUMATIC TUBING**
 - 2.5 INSTALL AND ADJUST BLADES**
 - 2.6 START-UP PROCEDURES**
- 3.0 MAINTENANCE**
 - 3.1 PERIODIC INSPECTION**
 - 3.2 ANNUAL INSPECTION**
 - 3.3 VIBRATION AND UNBALANCE**
 - 3.3.5 THROAT FLUTTER**
 - 3.4 WARRANTY**
 - 3.3.6 FIELD BALANCING**
 - 3.5 MANUAL FAN PARTS LIST**
 - 3.6 AUTOMATIC FANS PARTS LIST**
- 4.0 OPERATION**
 - 4.2 BLADE OVERLOAD**
 - 4.3 CAUSES OF IMPROPER BLADE LOADING**
 - 4.4 CHECKING BLADE LOAD**
 - 4.4.1 SAMPLE GRAPH OF BLADE ANGLE IN DEGREES**
 - 4.5 DAMAGING OPERATING CONDITIONS**
 - 4.5.3 OBSTRUCTIONS**

1.0 CLASS 10000 FANS OWNER'S MANUAL

1.1 ABOUT THIS MANUAL

Moore is as interested, as are its customers, that Moore fans operate at top efficiency for many, many years. This manual has been written to achieve that result and is based on more than fifty years of experience as a manufacturer of axial flow fans.

Moore fans represent the highest degree of axial fan development and are in all respects, regardless of price, the finest obtainable for their intended purpose. As for any fine equipment, certain precautions are necessary and certain abuses must be avoided in order to insure the best performance over the longest period of time. If you have any questions regarding the installation or operation of your Moore fan(s), please contact the Company for assistance.

1.2 INSPECTION

All Moore units are carefully balanced, inspected

and packed at the factory. If any damage is evident before or after unpacking, the delivering carrier should be promptly notified so that an inspection may be made by the claims adjustor. It is the responsibility of the consignee to file damage claims with the carrier. Although Moore will not be responsible for shipping damage, it is requested that any damage, even of a minor nature, be reported to the factory at once.

1.3 IDENTIFY YOUR FAN'S FEATURES

The installation instructions which follow will include some steps for installing fans with features not provided on your unit(s). Section 2 Getting Started should be read carefully before installation begins. Moore fans have several unique features. Those unfamiliar with these units should read the short summary of these important features on the last page of this manual.

2.0 INSTALLATION

2.1 GETTING STARTED

2.1.1 FAN IDENTIFICATION

Every fan, or group of identical fans, is assigned a Job Number. This number will be found on the Order Information Sheet showing fan specifications. A copy is attached to this manual. If non-identical fans are shipped together, a Job Number is assigned to each fan or group and a set of Information Sheets will be included for each Job Number.

The Job Number is written in semi-permanent ink on each blade, hub and air seal. All fan parts bearing the same Job Number are entirely interchangeable. (Blades of the same Series and Diameter are also interchangeable between Job Numbers.)

Fan components covered by more than one Job Number may be crated together. The Job Number that is written on each part, however, will make sorting simple.

Each individual fan produced by Moore is assigned a Serial Number. This Serial Number is embossed on a permanent metal tag and attached to each fan hub. The Fan Information Sheet provided for each Job Number lists all of the individual Serial Numbers of the identical fans covered by that Job Number so that, in future years, reference to the fan specifications provided will identify the characteristics of each individual fan.

Moore keeps records indexed by serial and job

numbers of all fans produced for at least forty years in order to provide proper maintenance advice and information on spare parts and replacements.

2.1.2 PLANNING THE INSTALLATION

The sequence given for the installation may be changed if the conditions warrant. For example, the air seal may be installed on the hub before the hub is installed on the drive shaft. (In fact, for inverted fans, it is necessary to install the air seal first.) The installation should be planned before beginning so that the steps required are taken in the most convenient order. If you need information not found here, please contact Moore.

Class 10000 fans are suitable for horizontal or vertical mounting, for electric motor or engine drive and may be designed for clockwise (right hand) or counterclockwise (left hand) rotation. **Note: Automatic fans can only be installed for horizontal applications. (Vertical shaft)**

Some drawings illustrating the installation assume vertical mounting and need to be mentally rotated for horizontal mounting. Be sure to refer to the dimensional drawing(s) provided. These will illustrate the proper orientation of the fan and the rotation direction.

2.2 INSTALL MANUAL HUB AND AIR SEAL

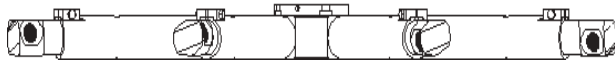

Hub Only Without Air Seal

Hub installation instructions

Moore Class 10000 hubs are shipped with Moore Hi-Torque (HT) Aluminum Bushings. The following paragraph details the installation procedure for these hubs.

Lubrication:

If the bushing was pre-installed in the hub at the factory, no further lubrication is required prior to installation.

If the bushing was not installed in the hub at the factory, it is imperative to apply high quality grease to the following surfaces:

1. The cap screw threads
2. The underside of the cap screw heads
3. The bushing taper / hub bore

DO NOT apply lubricant between the bushing bore and the shaft.

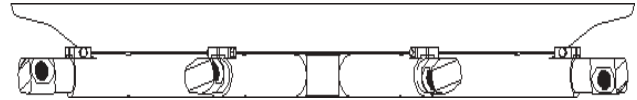

Air Seal Installed on Hub

Installation:

Install the bushing in the hub by aligning the threaded holes on the I.D. of the hub with the slots on the OD of the bushing with the cap screws captured between the bushing and the hub. Insert the bushing in the hub. Using a hex key wrench, sequentially tighten the socket head cap screws until the bushing is almost fully engaged in the hub. Leave slight play between the bushing and hub to facilitate installation on the shaft. Place the hub/bushing on the shaft. (Preferably cap screw heads will be towards free end of shaft.) Insert the key, and tighten the setscrew to secure the hub and key to the shaft. Now begin sequentially tightening the socket head cap screws (approximately 2-3 turns per cap screw initially) to firmly engage the bushing in the hub and seat the bushing on the shaft. Once the bushing/hub is firmly seated on the shaft, continue tightening the cap screws sequentially until the specified torque, shown in the following table, is reached. DO NOT over-tighten cap screws as this could cause damage to the hub.

Caution:

If bushing is expected to see frequent oscillating loads (Greater than 50% of nominal expected Static Torque), Fan should be operated for approximately 15 minutes and then re-torque bushing cap screws.

FAN HUB	Bushing TYPE	Bushing OD	Allen Head Bolt	Hex Key Size	Required Torque
	T	3"	12 mm	10 mm	50 ft-lb (6.9m-kg)
	U	4"	12 mm	10 mm	50 ft-lb (6.9m-kg)
	W	5.5"	16 mm	14 mm	90 ft-lb (12.5m-kg)
	X	5.5" Long	16 mm	14 mm	135 ft-lb (18.7m-kg)
	Z	7"	16 mm	14 mm	135 ft-lb (18.7m-kg)

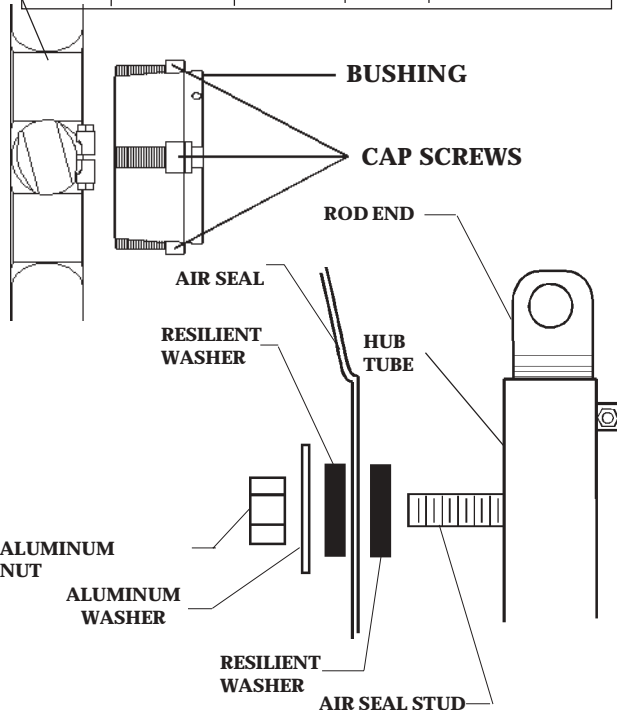

AIR SEAL INSTALLATION ON HUB

To install the airseal:

If the airseal is to be installed on the shaft side of the fan, cut out the center to provide clearance for the bushing.

Locate the air seal installation hardware in the plastic bag taped to one of the hub tubes. Install the air seal studs on the appropriate side of the hub tube. Finger tighten.

Place one resilient washer on each stud as shown in the drawings at left. Place the air seal onto the studs and install the remaining hardware, following the sequence shown in the drawings. Do not lubricate this end of the studs.

Note that the diameter of the resilient washers, before they are compressed, is slightly less than the diameter of the aluminum washer. Tighten each nut until the resilient washer's diameter is the same as the aluminum washer. Do not overtighten. Overtightness exists when the resilient washer has expanded in diameter larger than the diameter of the aluminum washer.

Note: Some air seals are provided with more mounting holes than may be required. This is done intentionally to make the air seals more interchangeable between units. For example, an air seal with 8 mounting holes can be used with either a 4-blade or an 8-blade unit.

2.3 AUTOMATIC HUB AND AIR SEAL

2.3.1 HUB INSTALLATION

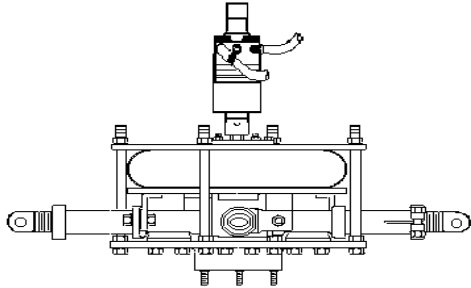

Automatic Hub Only Without Air Seal

If the (3) stainless steel bushing studs are not already installed in the fan hub, install them at this time. Hand-tighten only.

Slip the bushing onto the shaft and check the key for proper fit. Be sure the shaft is completely through the bushing but not extending beyond it. The end of the shaft should be flush with the top of the bushing.

Carefully clean the bore of the hub and the outside of the bushing with a clean, dry cloth. Use no lubricants in this installation. Use of lubricants can cause hub breakage.

Do not clean or alter the lubricant coating on the hex nuts.

Air seals are installed by the factory whenever crating requirements permit. If the air seal is already installed, lift the hub by grasping the hub tubes or clevises. Do not lift the hub by the air seal.

Lower the hub onto the bushing with the (3) stainless steel studs provided in the hub extending through the bushing flange.

Place the stud nuts on the studs and tighten the nuts alternately, keeping the pull on all of them as nearly equal as possible while drawing the hub onto the bushing until the bushing tightly grips the shaft. Caution should be used to prevent the hub from cocking on the bushing.

Tighten the nuts to the torque shown in the table at right. Do not over-torque. Excessive torque can cause hub or bushing breakage.

To install, **air seal** locate the air seal installation hardware in the plastic bag taped to one of the hub tubes. Remove the protective plastic caps from the bolts or studs. Place one aluminum washer and one resilient washer on each bolt or stud as shown in the drawings below. Lower the air seal onto the bolts or studs and install the remaining hardware, following the sequence shown in the drawings. Do not lubricate this end of the bolts or studs.

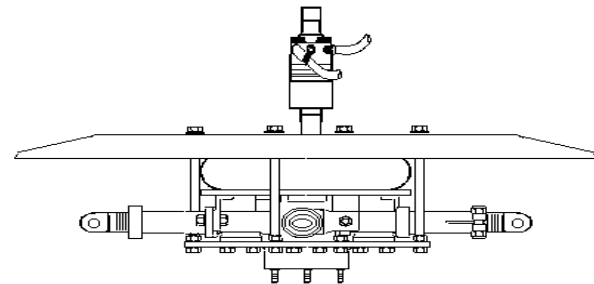
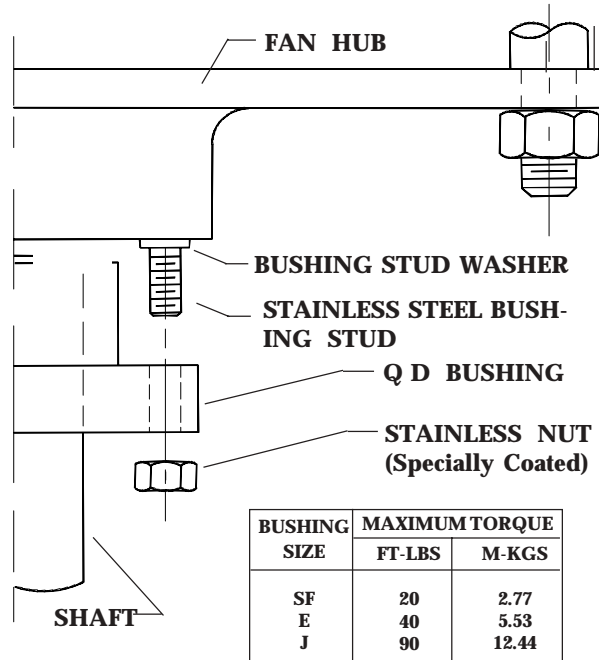

Air Seal Installed on Automatic Hub with Positioner

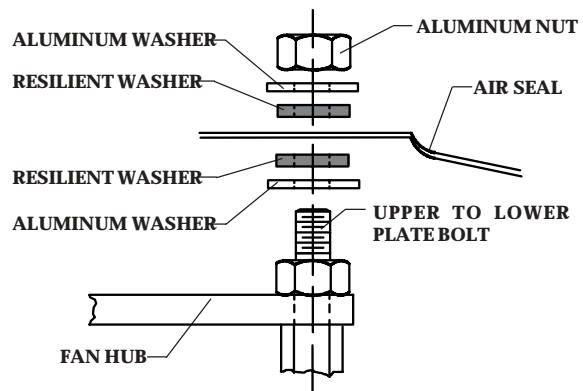

AIR SEAL INSTALLATION ON AUTOMATIC HUB

Note that the diameter of the resilient washers, before they are compressed, is slightly less than the diameter of the aluminum washers. Tighten each nut until the resilient washer's diameter is the same as the aluminum washer. Do not overtighten. Overtightness exists when the resilient washer has expanded in diameter larger than the diameter of the aluminum washer.

2.4 INSTALL PNEUMATIC TUBING

2.4.1 AUTOMATIC HUB WITH STANDARD POSITIONER

Connect the special flexible hoses provided to the instrument port "A" and the supply port "B" shown in the drawing. Use the elbow provided on one hose so that the hoses will be parallel. Support the positioner while tightening all fittings to prevent rotary union damage.

The flexible hoses supplied must be used and a **slight amount of slack should be left when connecting to rigid piping to relieve any abnormal loading of the rotary union internal bearings and seal.**

The ends of the hoses must be capped if not coupled to the system piping immediately. The flexible hoses provided terminate in 1/4" N.P.T. male fittings.

Flexible Hoses Connected to Supply and Instrument Ports on Positioner

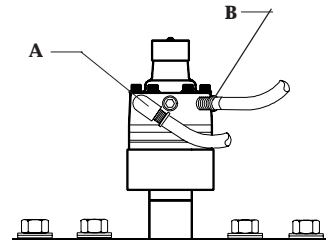

Pressure Requirements		
	P.S.I.	Kg/Cm ²
Control	3 to 15 (Std)	0.21 to 1.05 (Std)
Supply	35	2.45

MAXIMUM SUPPLY PRESSURE:
50 P.S.I. (3.5 Kg/Cm²)

2.4.2 FOR POSITIONER WITH FAIL LOCKED IN LAST POSITION

When a fan is specified to fail locked in last position, pressure is retained in the actuator chamber if the system pressure falls abruptly. This retained pressure prevents the blade angle from changing when a failure occurs in the system supply pressure.

Connect hoses "A" to the instrument port as described in 2.4.1. Hose "B", which is normally connected to the supply port is to be connected to the fitting labeled

"source air supply". The flexible hoses provided must be used and a little slack must be left in them to prevent damage to the bearing or seal in the rotary union.

When the system is charged, normal pressure at the valve keeps it in the open position and flow occurs in either direction between the positioner and the supply actuator. If the system pressure fails, the valve automatically closes, retaining pressure in the actuator.

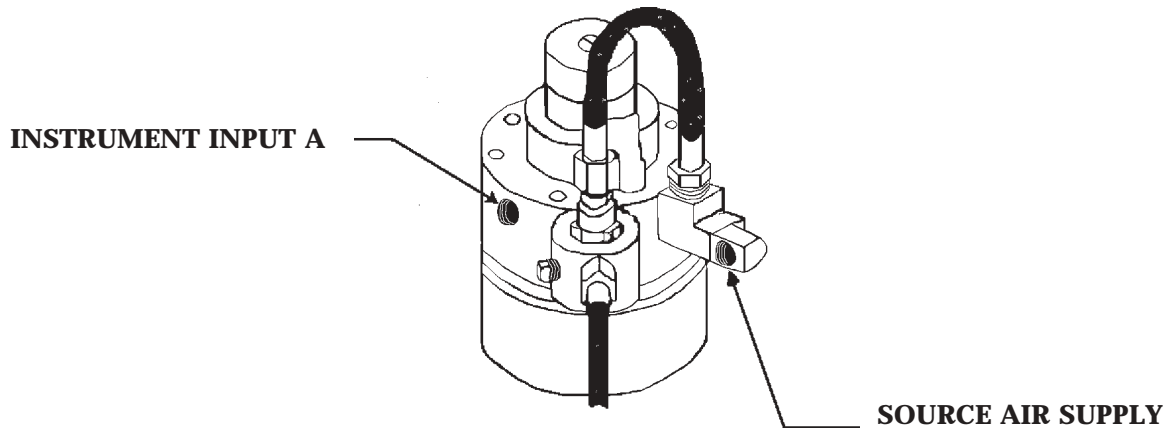

Note:
*After installing hub onto bushing: Check the hub and positioner for run out.
 Maximum run out of positioner in the horizontal direction is $\pm 1/8$ " (3mm)
 If outside the tolerance adjust the bushing nuts slightly to level the fan hub.*

2.5 INSTALL AND ADJUST BLADES

2.5.1 INSTALL BLADES

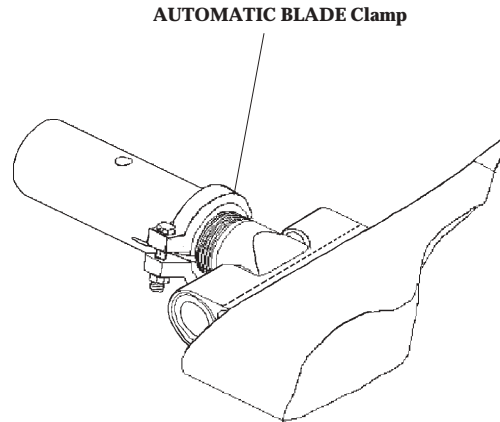
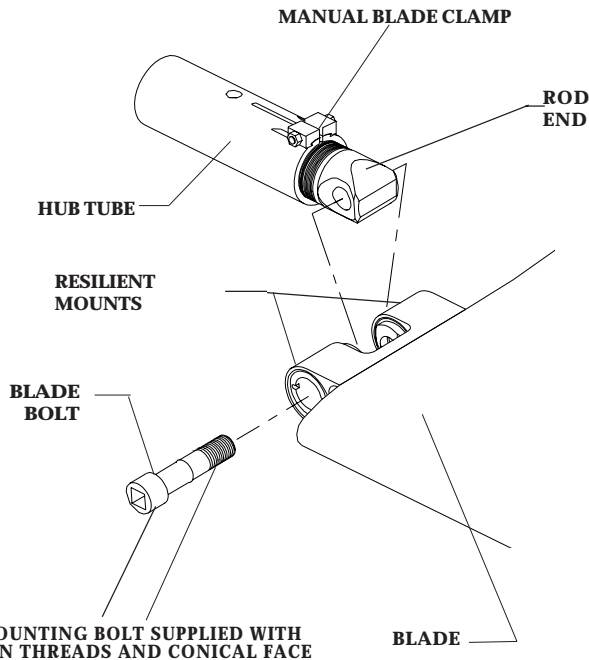

NOTE: AUTOMATIC Blade clamp's require higher torque setting see section 2.5.2

BEFORE INSTALLING BLADES. . .
 Check to see that the hub is level. If the drive shaft is not truly horizontal (or vertical), causing the hub to be cocked, it will be difficult to adjust blade angles accurately. Eccentric rotation of the fan can also cause serious vibration problems.
 If misalignment, vibration or unbalance in the system is present, it will be more easily identified and corrected at this time.

Moore fan blades are carefully balanced to the same moment at the factory. Any Class 10000 hub of the same series and diameter may be installed on any hub furnished on the job. They are completely interchangeable.

Moore Class 10000 Heavy Duty Fans are designed for engine drive and other applications with the more severe requirements of this service. Proper installation, with particular attention to tightening nuts to the specified torque, is essential to maintain the design integrity of these units.

Install one blade: Clean any dirt or grease from the rod end and the surfaces of the resilient mounts. Align the rod end hole with the holes in the resilient mounts and insert the blade mounting bolt first through the resilient mount with the recess to accept the bolt head, then through the rod end hole and screw the bolt into the second resilient mount

lightly. A 3/4" drive torque wrench with a short extension may be used. The blade mounting bolt is supplied from the factory with grease on the threads and conical face. **Do NOT clean the grease from the bolt.**

Complete the installation of one blade by holding the blade so that the blade extends straight out from the hub tube. Holding the blade in this position, **tighten the bolt using a torque wrench set to 200 ft-lb (28 m-kg) making sure the rod end and the resilient mounts seat.**

After installing the first blade, manually rotate the fan while moving the blade tip in and out to be sure the blade clears the ring or throat at all points. When the blade is held in alignment with the blade tube (that is, straight outward from the hub), it should clear the fan ring by a distance adequate to provide for any relative motion between the fan wheel and the ring. Excess clearance between the blade tips and the ring, however, should be avoided to prevent backflow which seriously reduces fan efficiency. If clearance is excessive, the diameter may be adjusted at this time. See Section 2.5.2.

Install the rest of the blades so that they are identical with the first blade. **Torque all bolts to 200 ft-lbs (28 m-kg).** If blades are installed properly, they will return to their undisturbed position if the tips are pressed in the axial direction with moderate force (10 to 20 lb).

2.5.2 ADJUST BLADE ANGLE

Hubs are shipped from the factory with the rod end set for the blade angle indicated by the design performance. A change in blade angle is sometimes necessary, however, to adjust to actual site conditions. Failure to adjust the blade

angle when required may result in blade overload. The causes of improper blade loading are explained in Section 4.3 of this manual. Section 4.4 "Checking Blade Load" provides a simple method of determining the maximum

blade angle allowable in terms of static pressure vs blade angle. Please refer to these sections before increasing blade angle.

To adjust, loosen the Clamp Nut just enough to allow the blade to be turned. Place a inclinometer on the flat surface of the mounts end as shown in the illustration at right. Turn the blade until the desired angle is achieved.. Make a permanent record of the final angle selected and take care that all blades on the fan are set at the same angle. A typical adjustment may be +/- 3°. **The maximum recommended blade angle is 30°.**

Retighten the Clamp Nut to 18 ft-lbs (2.5 m-kg) for Manual and 50 ft-lb (7 m-kg) for the Automatic while holding the blade in this position. ***Recheck each blade angle before tightening.***

WARNING: The fan is designed to consume the horsepower stated on the Fan Specification Sheet. The engine drive typically produces far more power than the fan can absorb. Too great an increase in blade angle can cause serious blade overload which will stall the blades. In this condition, the fan will actually deliver less air and blade life may be shortened. Blade load considerations are discussed in Section 4.0 Operation in this manual.

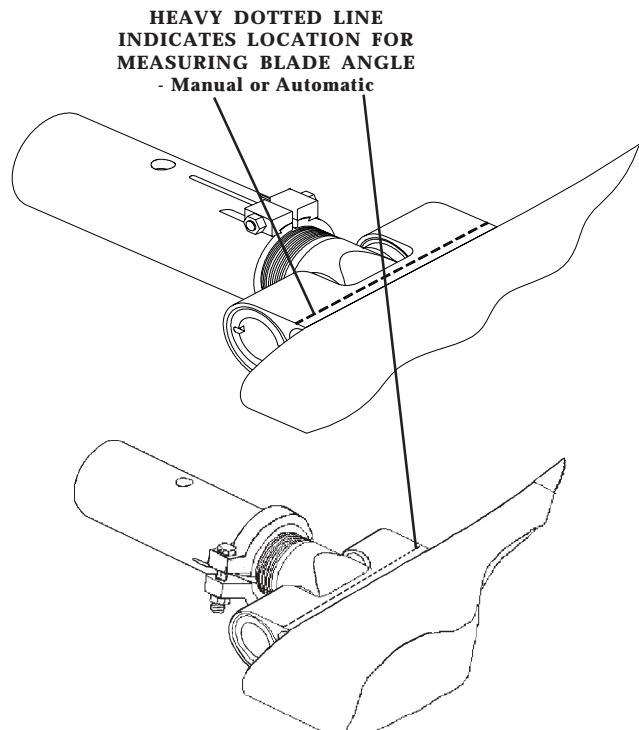

CLASS 10000 AUTOMATIC HUB DETAIL
NOTE: CLAMP DIFFERENCES

2.5.3 ADJUST DIAMETER IF REQUIRED

At times it may be necessary to adjust the fan diameter to suit a particular ring. To do so, loosen the clamp nut so that the rod end can be rotated in the hub tube. One complete revolution will increase or decrease the radius of the fan by .059" (1.5 mm) for manual and .087" (2.2 mm) for automatics. Take care that the clevis is returned to exactly the factory-set angle unless it is intended that the blade loading be

changed as discussed in the previous section. A match mark may be made at a point on the threads and the tube before turning to assure that exactly one revolution is made. **Tighten the clamp nut to 18 ft-lbs (2.5m-kg) for manual and 50 ft-lbs (6.9m-kg) for the automatic.**

Maximum adjustment possible is about +/- 0.75" (19 mm). At least 1.0" (25 mm) of rod end threads must remain in the tube.

2.6 START-UP PROCEDURES

Before starting the fan, manually check all bolts or nuts to see if they are tightened. Take care not to exceed the stated torque limits.

Manually rotate the fan while checking each blade for proper clearance.

Start the fan and watch it in operation. All blades should move to the same operating position, indicating that the blade angles are properly set and that all blades are equally loaded. If vibration or unbalance is evident, see Section 3.3.

After the fan has been operating for several minutes,

stop the fan and observe the blades as the fan comes to rest. All of the blades should return to their original position at the same rate.

Inspect the inner surface of the fan ring and the blade tips for any indication of scoring.

The horsepower given on the Fan Specifications is the calculated horsepower (at the fan shaft) that is required for the specified performance. Consult the factory or the fan curve before increasing the blade angle for the fan to consume more than the specified horsepower.

3.0 MAINTENANCE

3.1 PERIODIC INSPECTION

3.1.1 PURPOSE

Fan failure is most likely the result of destructive repetitive stress acting over a period of time. These stresses may be caused by mechanical abuse, e.g. rough gears or drive shaft imbalance, or by aerodynamic abuse such as blade overload or abnormal flow conditions. Fortunately, these stresses manifest themselves in typical ways that may easily be detected on inspection if one knows what to look for. The purpose of this section of this manual is to describe the symptoms of potentially damaging mechanical problems and how they can be corrected. Aerodynamic abuses are covered in Section 4.0 Operation.

3.1.2 FREQUENCY OF INSPECTION

The frequency of inspection varies widely in accordance with the severity of service and a suitable inspection schedule should be developed with experience over time. During the first week of operation, at least one inspection should be made. At these initial inspections, in addition to the items listed below, check all nuts for tightness to make certain that all were tightened properly at installation. Take care not to exceed the stated torque limits. Following the first week, it is probable that inspections of the fan need be made no more frequently than inspection of the drive.

3.1.3 BLADE ANGLE AND RUNNING POSITION

Turn off the unit and watch the blade tips. A looseness in the clamp bolt will permit a blade to flatten in angle. This usually can be detected by looking at the tips of the blades while the fan is slowing down. At the same time, before the unit comes to a complete stop, watch the track of the blade tips to see that all blades move to the same operating position. If one or more blades is at a substantially different position than the other blades, or if all of the blades are at a different position than at the last inspection, investigate further. This condition may be caused by a damaged resilient mount, requiring blade replacement.

3.1.4 CRACKS, DENTS AND CORROSION

Skin cracking may be caused by the tips dragging on the fan ring, or it may be the result of long-term fatigue due to continued operation under conditions of vibration or unbalance as discussed in Section 3.3 which follows. Skin cracking can also be caused by continued operation under overload conditions as discussed in Section 4.3 Causes of Blade Overload.

Cracking in air seals can occur if the airseal has been improperly installed. See Section 2.2. Check to be sure the resilient washers are present and the nuts properly tightened.

The fatigue strength of materials, whether metal or plastic, may be lowered by long-term exposure to water.

Dents in blades are caused by objects falling into the fan or the fan striking some obstacle. Minor dents may sometimes be repaired by drilling a small hole in the center of the dent and pulling outward on the blade skin. Blades may be ordered from the factory for replacement. If there is any evidence of this type of damage, the hub should be carefully inspected as discussed in Section 3.1.6 which follows.

The Type 5052 aluminum, a marine alloy, used as the blade material on Moore fans works well with either fresh or sea water. Waters that are acid, alkaline, or contain copper salts, however, should be avoided for all aluminum alloys. If you have questions regarding the suitability of the fan materials under certain water conditions, please contact the factory.

3.1.5 HUB INSPECTION

If damage to the fan has occurred, the hub should be carefully inspected since subtle damage may have been caused that is not readily apparent. Check the hub for any sign of bending or twisting of the hub tubes. Hub tubes cannot be replaced in the field on manual fans and a new hub should be ordered.

Bushings are frequently cracked during a fan wreck and should be carefully inspected. Damage may occur to the studs that attach the hub to the bushing. It is a good idea to replace the studs when replacing a damaged fan blade.

As with any industrial equipment, before entry into fan chamber, strict adherence to ALL Lock-out / Tag-out procedures is well advised!



3.2 ANNUAL INSPECTION

3.2.1 CLEAN BLADES IF INDICATED

A smooth blade surface is essential for efficient fan performance. If an incrustation forms on the blades it should be removed. Use steel wool as an abrasive along with a mild detergent or a very mild form of solvent. Lye must not be used because it attacks aluminum readily.

3.2.2 CHECK SYSTEM PRESSURE

Radiator sections may be effected by the accumulation of dust and dirt in some atmospheres. (Cottonwood seeds are particularly troubling.) These accumulations may significantly increase the static pressure. Adjust the blade angle if necessary as described in Section 4.4 Checking Blade Load.

3.2.3 CLOSE INSPECTION

The yearly inspection should be a very thorough one. All nuts and bolts should be checked and careful scrutiny given to all highly stressed areas.

Inspect the resilient mounts as follows: With the fan turned off, grasp each blade and feel for looseness at the mount. If in doubt, the blade should be removed and the mount assembly visually inspected. Wear is indicated by a fretting effect and the resilient mount material will show signs of extruding from the cavity. If these indications are not apparent, replace the blade and continue normal operations.

Inspect the blade tips for any signs of cracking and the fan ring for any scoring that might indicate that the blades have been striking or rubbing against the fan ring.

3.3 VIBRATION AND UNBALANCE

3.3.1 GENERAL

No piece of rotating equipment is perfectly balanced. It is always possible that the minute unbalances of the various components may combine to provide a noticeable lack of balance. This rarely occurs, since it is unlikely that all unbalanced components will become assembled with their heavy sides in the same direction. Nevertheless, if unbalance is noted, the various components should be rotated into different positions to see if this might cure the unbalanced condition.

If vibration or unbalance occur, either at the time of installation or later during the operation of the unit, its cause may be determined by following the directions below.

3.3.2 FAN UNBALANCE

Vibration is most likely to be caused by the fan if the blades are not set at the same angle. If the blades are properly set, the fan is the least likely cause of vibration. All fan components are balanced to within ± 0.2 ft-lbs.

If the fan is in an unbalanced condition, the frequency of vibration of the structure will be that of the RPM of the fan and is quite low. In the case of large fans, the frequency is often low enough to be mentally counted along with the rotation of the fan. A vibration of 500 RPM or less will be felt as a weave in the structure rather than a vibration. Below 400 RPM, the vibration may be mentally counted and above that point may be read with a frequency meter.

Before assuming fan unbalance, check for loose bearing seats or bearings journaling the shaft on which the fan is mounted. This condition will cause the shaft to rotate eccentrically, throwing the weight of the fan off-center, resulting in unbalance of the frequency of the fan RPM.

After all checks have been made and the fan is still determined to be unbalanced, field balancing may be accomplished as described below in Section 3.3.6.

It should be noted that the loads imposed on the drive shaft and its supporting bearings by fan unbalance

are negligible. A rotating centrifugal load of 100 pounds, due to unbalance, would be extremely objectionable and possibly even damage the structure on which the drive was mounted. By contrast, it would be unlikely that the drive shaft of a fan, of perhaps 25 HP, would be supported on bearings rated less than 2000 or 3000 pounds radial load. For higher horsepowers, the bearing capacity would be correspondingly increased. From this it is evident that speed reducer or drive shaft bearing failure could never be caused by moderate or even objectionable fan unbalance.

3.3.3 BELT DRIVE UNITS

The more common causes of vibration in belt drive units are not the drives themselves but the result of shafts that are too flexible or non-rigid supporting members. Vibration can be caused by misalignment of the sheaves or poorly adjusted belt tension. Consult the manufacturer of the drives for information. The quickest way to identify the cause of vibration in belt drive units is to operate the fan with the blades removed.

3.3.4 ROUGH GEARS

Continued operation on rough gears and bearings is almost certain to develop cracks in the blade skins. Rough gears may be of two types:

1. Rough or failed bearings in the drives or gears will result in a high frequency vibration being transmitted into the fan where some areas of the skin will respond to the frequencies applied. Cracks will appear in the blade skin and eventually, in some areas, the skin may actually fall away.

2. The other type of rough gear occurs when the output shaft accelerates and decelerates with each pinion tooth engagement. With a six tooth pinion and a motor speed of 1800 RPM, or 30 cycles per second, this gear misalignment impresses upon the fan a vibrating frequency of $30 \times 6 = 180$ cycles per second. If the engagement of teeth is also included, the frequency is 360 cycles per second. This type of high frequency vibration is at least as serious as that caused by bad bearings.

3.3.5 THROAT FLUTTER

Any fan that is effectively moving air at the tips of the blades will develop a reduced pressure area (or suction) on the fan throat or ring at the tip of the blade. This suction tends to draw the throat toward the tip of each blade, which means that a four blade fan would tend to draw the throat into something approaching a square while a six blade fan would draw it into something resembling a hexagon, etc. Since the fan is rotating, the effect on the throat is that of continually drawing it into a rotating polygon. The resulting throat flutter is frequently mistaken for fan unbalance.

A substantial throat or ring will be sufficiently rigid that flutter will not exist. A weak or flexible throat, particularly when used with a fan of a low number of blades, will be greatly affected by this type of vibration. Throat flutter is easily detected due to the fact that it is invariably of a frequency of the fan RPM times the number of blades on the fan.

Throat flutter will cause no damage to the fan so long as the throat does not disintegrate and fall into the fan blades. It may be eliminated by stiffening or bracing the throat.

If in doubt that throat flutter is the cause of

vibration, reduce the angle of the blades until the fan is doing little or no work. If the vibration ceases under this condition, it is certain that throat flutter is present when the blades are loaded.

3.3.6 FIELD BALANCING

Unbalance in older fans may develop because of some structural change or by installing one new blade on an old fan where the existing blades had changed in weight in the course of operation.

Use wire to attach a small weight in succession to each of the air seal studs until the best location for the weight is found. The weight should then be increased or decreased until the best balance is achieved. The permanent weight may then be secured to the stud or hub tube, whichever is the most convenient for the type and shape of weight to be used. One or more pieces of metal shaped like a washer could be placed over the stud, on the hub tube, behind the stud, or over the threaded portion of the rod end. Aluminum or stainless weights should be used and weights should not be attached to the blade skin.

3.4 WARRANTY

MOORE FANS LLC (the Seller) warrants only to Buyer, as its purchaser for resale, that the fans manufactured and sold by Seller to Buyer under this Agreement will be free from all defects in material and workmanship under ordinary use for a period of two (2) years from the date of shipment or one (1) year from the date the fan is installed on a customer's premises, whichever occurs first. This warranty period shall apply only if Seller receives written notice of any defect within the warranty period. Upon receipt of such notice, Seller, at its option, may require Buyer to return the fan at Buyer's cost to Seller for inspection by Seller. If the fan is found to be defective on inspection by Seller, as a sole and exclusive remedy, Seller will, at its option, either repair or replace the fan. This warranty shall not

apply to damage on account of misuse, neglect or accident or shipping damage, or if repairs or part replacements have been made or attempted without Seller's prior written authorization. SELLER SHALL NOT BE LIABLE IN ANY EVENT FOR ANY INCIDENTAL OR CONSEQUENTIAL DAMAGES FOR BREACH OF THIS OR ANY WARRANTY. THIS WARRANTY IS IN LIEU OF ALL OTHER GUARANTEES OR EXPRESSED WARRANTIES AND ALL IMPLIED WARRANTIES, INCLUDING THE IMPLIED WARRANTIES OF MERCHANTABILITY AND OF FITNESS FOR A PARTICULAR PURPOSE. DUE TO THE VARIETY OF CONDITIONS UNDER WHICH THE FANS MAY BE USED, RISKS OF RESULTS OBTAINED FROM USE OF THE FANS, WHETHER USED ALONE OR IN COMBINATION WITH OTHER PRODUCTS, IS ENTIRELY BUYER'S. THE ABOVE LIMITATIONS ON DAMAGE AND EXCLUSION OR LIMITATION OF IMPLIED WARRANTIES ARE NOT APPLICABLE TO THE EXTENT PROHIBITED BY STATE LAW.

3.5 MANUAL FAN PARTS LIST

NOT TO SCALE: SOME DIMENSIONS AND ANGLES HAVE BEEN EXAGGERATED FOR CLARITY

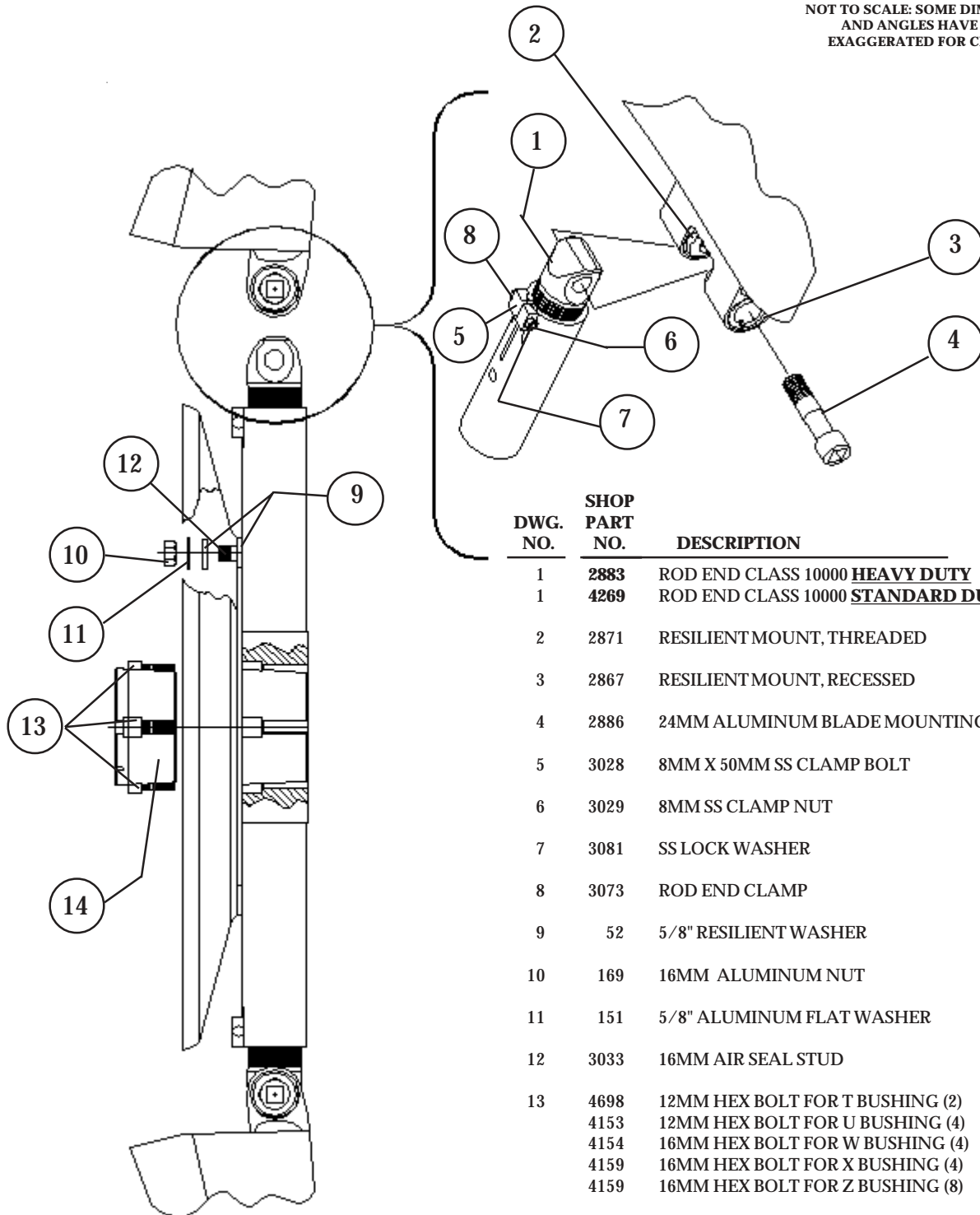

DWG. NO.	SHOP PART NO.	DESCRIPTION
1	2883	ROD END CLASS 10000 HEAVY DUTY
1	4269	ROD END CLASS 10000 STANDARD DUTY
2	2871	RESILIENT MOUNT, THREADED
3	2867	RESILIENT MOUNT, RECESSED
4	2886	24MM ALUMINUM BLADE MOUNTING BOLT
5	3028	8MM X 50MM SS CLAMP BOLT
6	3029	8MM SS CLAMP NUT
7	3081	SS LOCK WASHER
8	3073	ROD END CLAMP
9	52	5/8" RESILIENT WASHER
10	169	16MM ALUMINUM NUT
11	151	5/8" ALUMINUM FLAT WASHER
12	3033	16MM AIR SEAL STUD
13	4698	12MM HEX BOLT FOR T BUSHING (2)
	4153	12MM HEX BOLT FOR U BUSHING (4)
	4154	16MM HEX BOLT FOR W BUSHING (4)
	4159	16MM HEX BOLT FOR X BUSHING (4)
	4159	16MM HEX BOLT FOR Z BUSHING (8)
14		T BUSHING (3") U BUSHING (4") W BUSHING (5.5") X BUSHING LONG (5.5") Z BUSHING (7")

3.6 AUTOMATIC FANS PARTS LIST

HUB TYPE CSP

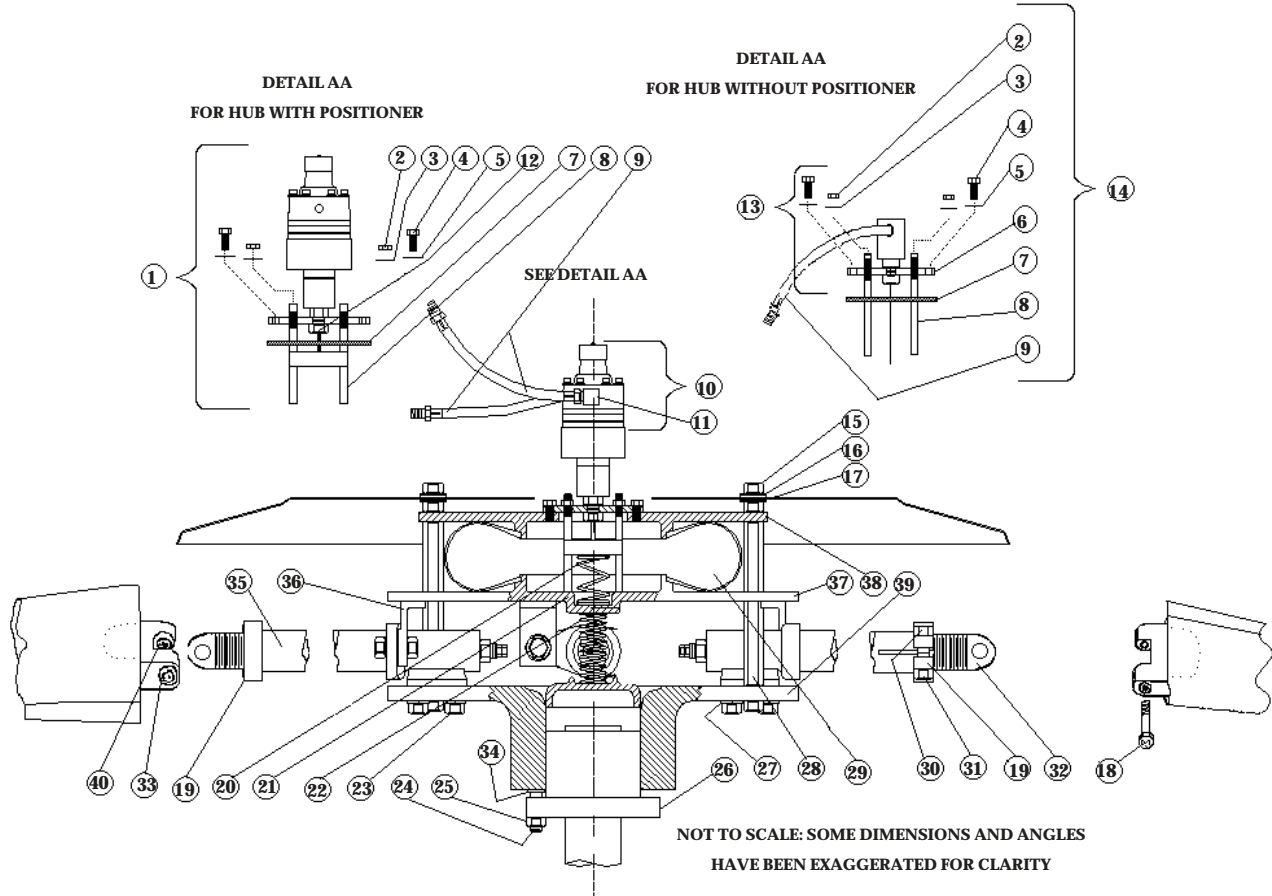

DWG. NO.	SHOP PART NO.	DESCRIPTION
1	2624	CSP UNION ASSEMBLY (WITH POSITIONER)
2	1625	10MM STAINLESS STEEL NUT (3)
3	733	3/8" SEALED WASHER (3)
4	771	10 MM X 30 MM STAINLESS STEEL BOLT (6)
5	179	3/8" FIBER WASHER (6)
6	162	UNION PLATE
7	163	UNION PLATE GASKET
8	159	STAINLESS STEEL STOP STUD (3)
9	257	12" STANDARD STAINLESS STEEL AIR HOSE ASSEMBLY WITH 1/4" NPT EXTERNAL THREADS BOTH ENDS
10	21	POSITIONER
11	210	1/4" BRASS STREET ELL
12	344	5/8-18 LH LOCKNUT
13	264	CS ROTARY UNION
14	186	CS UNION ASSEMBLY WITH HARDWARE
15	1532	18 MM ALUMINUM HEX NUT
16	164	3/4" ALUMINUM FLAT WASHER
17	52	5/8" RESILIENT WASHER
18	2886	16 MM X 108 MM ALUMINUM CLEVIS/BLADE BOLT
19	644	SMALL CLEVIS CLAMP
20		RANGE SPRING
21		RETURN SPRING SHIM
22		RETURN SPRING

DWG. NO.	SHOP PART NO.	DESCRIPTION
23	1616	10 MM X 45 MM ALUMINUM ANCHOR TEE BOLT (4/BLADE)
24	1345	10 MM S S STUD FOR QDSF BUSHING (3)
	1347	12 MM S S STUD FOR QDE BUSHING (3)
	1558	16 MM S S STUD FOR QDJ BUSHING (3)
25	1346	10 MM S S NUT FOR QDSF BUSHING (3)
	1348	12 MM S S NUT FOR QDE BUSHING (3)
	1559	16 MM S S NUT FOR QDJ BUSHING (3)
26		QDE, QDJ, QDSF TYPE BUSHING
27	152	5/8. ALUMINUM LOCK WASHER (4/BLADE)
28	1530	18 MM X 302 MM ALUMINUM HUB STUD
29	16	DIAPHRAGM ACTUATOR
30	167	16 MM X 70 MM ALUMINUM BOLT (FOR ROD END CLAMP)
31	169	16 MM ALUMINUM NUT ROD END
32		ROD END
33	2872	SMOOTH BORE MOUNT
34	2871	THREADED MOUNT BUSHING STUD WASHER
35		HUB TUBE ASSEMBLY WITH HARDWARE
36		PISTON STRUT ASSEMBLY WITH HARDWARE
37		PISTON PLATE
38		CYLINDER PLATE
39		HUB PLATE

4.0 OPERATION

4.1 AERODYNAMIC ABUSE

4.1.1 ABOUT THIS SECTION

It is widely acknowledged that the kinds of mechanical abuse described on the preceding pages are destructive for all types of operating equipment. It is less well recognized that — for fans — aerodynamic stresses are an even more serious hazard. This section deals with the causes of destructive aerodynamic stresses and how they can be avoided.

Although this information is given primarily for the benefit of operators of Moore equipment, it may be applied to fans of any manufacture.

Unlike smaller fans, which are typically furnished complete with their surroundings, the large fan wheel is supplied as an unprotected component of the system and is installed in innumerable types of surroundings. Not only do the types and conditions of the drives for these fan wheels vary widely, but the entrance and exit conditions and the enclosure for the wheel assume a myriad of possible combinations. In designing his product, the manufacturer of fan wheels must anticipate the operating conditions based upon his knowledge of what is reasonable and customary for the industry. He may over-design for abnormal stresses only until the practical limit is reached to avoid excessive weight, cost and inefficiency.

4.1.2 NORMAL OPERATING CONDITIONS

The fan manufacturer assumes a fairly reasonable atmosphere for the operation of his product, including the following:

- The fan selection will be reasonably in line with the performance the unit is expected to maintain, with an adequate blade area for the pressure required at the given RPM. Blades will not be loaded beyond their capacity to maintain air flow.
- A fan ring will be provided that is round, rigid and of a depth at least sufficient to cover the tips of the blades. Tip clearances will be uniform and controlled.
- The approach air will represent a relatively uniform and axial flow with, of course, some unavoidable turbulence expected. Adequate open area will be provided at the inlet of the fan.
- Major obstructions will not be present at either the inlet or discharge of the fan.
- The RPM of the fan will be within the design limits.
- The relative direction and velocity of approaching air to the blades will be fairly constant and protection will be provided from extreme wind conditions.

Under such conditions, the unit stresses in the blades would not be expected to vary more than plus or minus 50%. Fan design based on such assumptions is entirely reasonable and, with proper drives and installation conditions, has proven highly successful.

4.1.3 ABNORMAL CONDITIONS

Abnormal operating conditions result in destructive repetitive stresses that can seriously shorten fan life. The aerodynamic abuses discussed in this section can cause repeated flexing of the fan blades and hub. Violent displacement of the resiliently mounted Moore fan blades may occur — a greater displacement than would occur in rigidly mounted blades. The resilient mounting, of course, minimizes the structural unit stresses which would be transmitted to the root of the blade and into the hub and drive. Although Moore units may be expected to resist greater stress than units of conventional design, such repetitive stresses may exceed the capability of the resilient mounts to absorb them. If so, fatigue of the mounts and metal may develop, adjusting linkages may wear, and ultimate failure becomes a possibility.

Some of the abuses set out in the following text are far less important than others. All of them may occur in varying degrees.

Specifically, abuse due to serious repetitive stresses can lead to mount failure and, if carried to extremes, can require blade replacement. In units of other manufacture with rigidly mounted blades, repetitive stresses of this type may lead to blade breakage, probably near the root or at the point of attachment to the hub where stresses are highest, or may lead to failure of the hub itself. The resilient mount design, unique with Moore fans, dampens these vibrational forces and results in a fan that is far less vulnerable to failure from these conditions than other units with rigidly mounted blades. Even so, extreme conditions can cause damage.

A well-designed fan can be expected to operate for many years without trouble under normal operation as described above. The extreme repetitive stresses described below, however, will certainly reduce the life of the fan, causing failure many years sooner than would occur if the fan were operated as intended. Fortunately, these destructive conditions are readily observable to someone who is knowledgeable about them, and they can be corrected with reasonable effort and expense once they are observed.

4.2 BLADE OVERLOAD

Of all the aerodynamic abuses to be avoided in the operation of a fan, the most important is that of overloading the fan blades. Blade overload occurs because of insufficient blade area: In other words, when there is an inadequacy in the number of blades on the fan selected.

The Moore system of rating is based upon the pressure that each blade will produce at a given RPM with good efficiency. This pressure is called 100% blade load. When blade load exceeds 110%, the fan will not only operate at lower efficiency, it may be subject to structural damage as well.

In selecting a fan, the total pressure divided by the pressure to be produced by one blade determines the number of blades required for the anticipated performance. Whenever information is available, The Moore Company checks the selection. Even so, underestimation of the pressure requirements by the system designer, or changes in the operating conditions over time, may result in overload conditions.

Why is a blade overload condition of such concern? We are all aware of the fact that an airplane traveling at a given speed can carry only a certain load. If the speed of the airplane is decreased or the load increased, stalling flow over the wing will occur. In the case of an airplane, approximately two-thirds of the lift provided by the wing is the result of the air flow over the top or convex portion of the wing. Lift is provided as a reaction to the flow of air being accelerated and deflected downward as it passes over the wing. A negative pressure area is thus formed on the top surface of the wing which tends to lift it upward.

So long as air flow over the wing is smooth and clings to the surface of the wing, little turbulence is present. When the load is increased, or the speed decreased, the angle of the wing to the air stream must be increased to a point where the air flow breaks away from the upper surface of the wing. This is known as stalling or burbling flow, since the air, instead of clinging to the wing, breaks away near the leading edge and leaves what might be called a turbulent void above the upper wing surface, nullifying the accelerated flow which was responsible for the greater part of the lift of the wing.

When this occurs, the wing loses a large portion of its lift. Flow, however, will re-establish briefly and break again, the cycle being repeated continuously, resulting in a severe

vibration throughout the aircraft as the flow alternately makes and breaks. Anyone who has experienced a stall in an airplane will be familiar with this violent phenomenon.

A fan blade is no different than an airplane wing except that the air usually is being deflected upward rather than downward, the convex side of the blade being the lower surface rather than the upper surface as in the case of an airplane. The result of blade overload is identical: When blade load exceeds that allowable, a violent vibration will take place in the blade as the laminar, or uniform, flow makes and breaks perhaps many times a second.

Another way of looking at this problem is to consider that the available number of blades are set at too steep an angle to be able to move air at the axial velocity which is necessary to maintain a smooth flow over the convex surface. In other words, to move air at the velocity necessary for this blade angle, plus overcoming the static resistance of the system, the total pressure which would have to be maintained for an air flow corresponding to this angle is greater than the total pressure capability of the given number of blades at this RPM. Such a condition can only be corrected by decreasing the blade angle until smooth flow is obtained or by increasing the number of blades and the total pressure potential of the fan until the fan's pressure potential equals the pressure necessary to move the specified quantity of air through the system.

Continued operation under conditions of stalling flow, or blade overload, will significantly shorten the life of the fan. Operation under these conditions will also reduce efficiency to a ridiculously low figure. See the chart under Section 4.4 Checking Blade Load which follows. Note that although air flow remains constant or decreases, horsepower continues to increase with increased blade angle.

In conclusion, if a given fan, in a given installation, can only absorb forty horsepower, for example, the blades may be pitched up to consume fifty horsepower without any increase in air delivery, and possibly with a decrease. As a result, the extra ten horsepower is totally wasted -- perhaps worse than wasted. It is good practice to select a sufficient number of blades so that blade load will amount to slightly less than 100% of full blade load

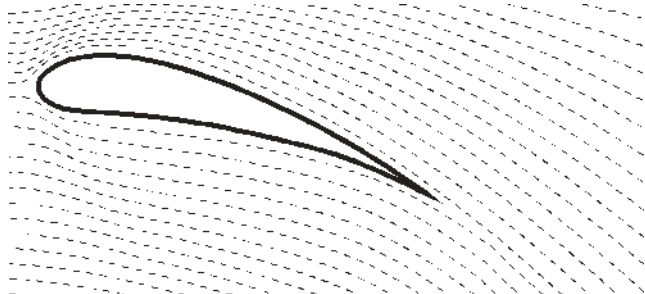

AIRFLOW IN NORMAL FLOW
Downward flow provides lift to the wing

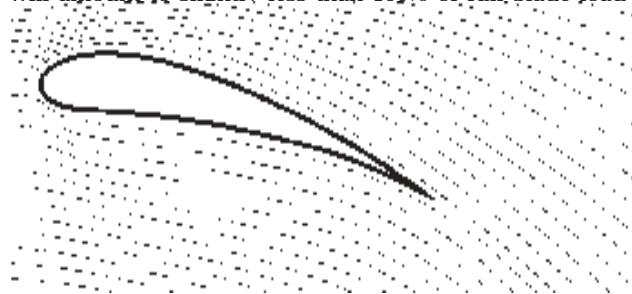

AIRFLOW IN STALLING FLOW
Note lack of air deflection downward.

4.3 CAUSES OF IMPROPER BLADE LOADING

4.3.1 VARIATION FROM PREDICTED CONDITIONS

Although those who design air coolers and cooling towers undoubtedly do their best to accurately state the calculated static resistance of the system, a number of factors may cause the actual conditions to vary from the design conditions. When a variation occurs, it may be found, upon testing, that the static pressure for a given volume through the system is higher than anticipated. In this case, the number of blades provided may be inadequate to meet the performance. On the other hand, the static pressure may have been overestimated and excess blade area provided, resulting in a fan with unutilized capacity operating at low efficiency.

Inadequate Blade Area: The blade angle is selected to move the anticipated volume of air and the number of blades is selected to maintain the total anticipated pressure required to move this volume at a given RPM. If the static pressure turns out to be higher than predicted, the fan may then be operating in an overload condition. If the RPM cannot be increased, the only solution to this condition is to reduce the blade angle until the fan can carry the then reduced volume at the originally anticipated pressure. Since reducing the volume, while holding the total pressure as originally anticipated, can only reduce the horsepower, it is then impossible to consume the horsepower originally intended without overloading the fan. This is one of a number of reasons for providing some safety factor in blade loading at the time of original fan selection.

Excessive Blade Area: Occasionally, an excessive number of blades may be specified in the interest of making a conservative selection. If the static pressure has been overstated, the theoretical number of blades will be greater than needed. This theoretical number of blades is usually a fractional number and the actual number of blades used must, of course, be the next larger integer, resulting in some "safety factor" in the selection. If, in addition, a blade or two is added as a "safety factor" or in anticipation of increased future requirements, it may be impossible to meet the original performance requirement efficiently. The only way to provide the original performance and draw no more than the original horsepower is to flatten the blade angle. There is a limit, however, in how far the blade angle may be reduced before further reduction will decrease airflow without a further reduction in horsepower. For belt drive units, the most practical solution to this problem is to reduce the RPM of the fan.

4.3.2 EXCESSIVE TIP CLEARANCE

Unless the fan ring is very close to the tip of the blade, air from the high pressure surface of the

blade will flow around the tip and nullify the negative pressure on the underside of the blade for some distance in from the tip. For a fan of, say, 12-ft diameter, the last 12 to 18 inches of the blade could be producing no pressure whatever and performing no useful function. The balance of the fan blade toward the hub then must produce a higher pressure to compensate for the portion near the tip.

Excessive tip clearance also leaves an unswept area between the tip of the blade and the fan ring. Air that has been pumped by the fan will return downward through this unswept area at a velocity greater than that at which it passed through the fan in the desired direction. This condition adds even further to the requirements of the portion of the blade which is doing the work and efficiency will be greatly reduced.

With the loss of a foot at the tips of the blades, plus the back flow between the tips and the ring, the 12-ft fan in this example might be considered an effective 10-ft fan. It would have to deliver sufficient air to satisfy the performance requirements of the installation, plus the amount of air which is returning in the void between the tips and the throat. Under such circumstances, excessive blade loading could occur even though the required system pressure is not achieved.

4.3.3 POOR ENTRANCE CONDITIONS

Air will approach the fan from all possible directions, increasing in velocity as it nears the opening, then accelerating rapidly as it enters. The air approaching from the side must be turned through 90° to enter a ring whose entrance terminates in a flat plate. If the inlet end of the ring projects some distance out, with approach possible from all directions, a portion of the air must be turned through 180°. The inertia of the approaching air prevents it from turning sharply and advancing parallel to the desired flow. It consequently swoops toward the center, leaving the outer area of the fan with reduced flow or even reverse flow near the ring.

The effect of poor entrance conditions is similar to that previously described for excessive tip clearance in that the effective diameter has been reduced and excessive blade loading could occur even though the required system pressure is not achieved. Efficiency will be greatly reduced.

4.3.4 EXCESSIVE DEFLECTION

The pressure which the fan can achieve is dependent upon the square of the velocity of the blades relative to the air. If the air could be moved into the fan in an axial direction and passed through the fan into the discharge without changing direction, the relative velocity of the blades to the air stream would be the true velocity of the blades at any point. This, of course, is not the case. For the blades to accomplish work upon the air, they must also deflect the air in the direction of rotation of the fan. The air when rotated with the fan is moving with

a certain velocity in the same direction as the rotation of the fan, which reduces the relative velocity between the fan blades and the air by some portion of this rotational velocity.

Moore fans are designed in contemplation of a maximum deflection of 50° at the hub, decreasing to a very small value at the tip. This deflection is considered in the determination of the pressure which may be provided by each blade over its full length. If fans are selected, or if conditions exist, which cause the deflection to exceed 50° at the hub, the velocity of the blades relative to the air is less than anticipated and the blades will not provide the rated pressure. The test below, however, will show the full allowable pressure

capability of the fan, even though it does not reach the full rated pressure.

4.3.5 CONCLUSION

As can be seen by the various points discussed in this section, there are a number of complex factors which tend to cause fans to be operated in a condition of improper blade loading which can shorten fan life or lower efficiency. When blade angles are set to consume the specified horsepower (at the fan shaft), the resulting performance should be very close to the specified performance. If this is not the case and the problem cannot be identified or corrected, please contact Moore for assistance.

4.4 CHECKING BLADE LOAD

One method of checking blade load is to run a complete field test on the fan. Although laborious, this method will provide ample proof so long as neither excessive tip clearance nor poor entrance conditions are present. If either are present, however, the conditions set out above under Section 4.3.3 would apply and the fan could be overloaded even though the total pressure indicated by the test was within the allowable blade loading.

A better, more convenient and simpler method of detecting blade overload, or determining maximum allowable blade angle, is set out below. The equipment needed is a wrench, a torque wrench, a protractor and a draft gauge (or manometer).

All fans are shipped with the blade angle set for the anticipated performance requirements furnished to The Moore Company by the purchaser. This blade angle is called out on the Fan Specification Sheet. This angle refers to the angle measured at the location shown in Section 2.3.3. Hubs are shipped with the clevises set at this angle.

To start the test, adjust the blades to an angle of approximately half that called out on the specifications or measured on the units. Connect the draft gauge to as quiescent a spot in the plenum as possible, preferably in the corner of the plenum and either ahead of or following the fan, depending upon whether the application is induced or forced draft. Since the figures obtained are purely relative, it is not necessary that accurate static pressure readings be obtained, but rather that the readings taken represent a consistent series of pressures at the point of reading chosen.

Start the fan and record on the chart provided the blade angle and the static pressure indicated. Advance the blade angle by one or two degrees and repeat the performance, recording again these read-

ings. Keep increasing the angle and following this procedure until the motor is fully loaded, in which case the fan is able to consume full rated fan horsepower without overload OR until the curve which will have started on a definite slope begins to approach the horizontal. It will be noted that the static pressure will be consistently increasing with increased blade angle until the blade loading reaches maximum, at which point it will level off.

Subsequent increases in blade angle may have quite different effects, depending on the individual installation. The static pressure curve may merely stay level or may drop off sharply. In rare cases, it may level off and again start rising as the fan begins operating as a centrifugal blower.

Typical examples are shown in dotted lines on the chart opposite. Operation beyond the first point of levelling, or in the area of the dotted lines, is indicative of blade overload. Note that power consumption load will continue to increase even though the fan has passed into overload condition. The maximum blade angle allowable is that which produces a static pressure about 5% below the point where the curve becomes level. This represents a safe loading, and the blades may be set and left at this angle regardless of the location on the chart, assuming the motor is not overloaded.

The point so selected will also approximate the point of the most efficient operation of the fan. Due to possible error in static pressure predictions, or in readings which are intended only to be relative, as well as other variables, the final blade setting chosen may fall below or above the specified static pressure.

A typical performance chart is shown opposite for a fan capable of a higher blade loading than originally specified. A blank chart is also provided for your use.

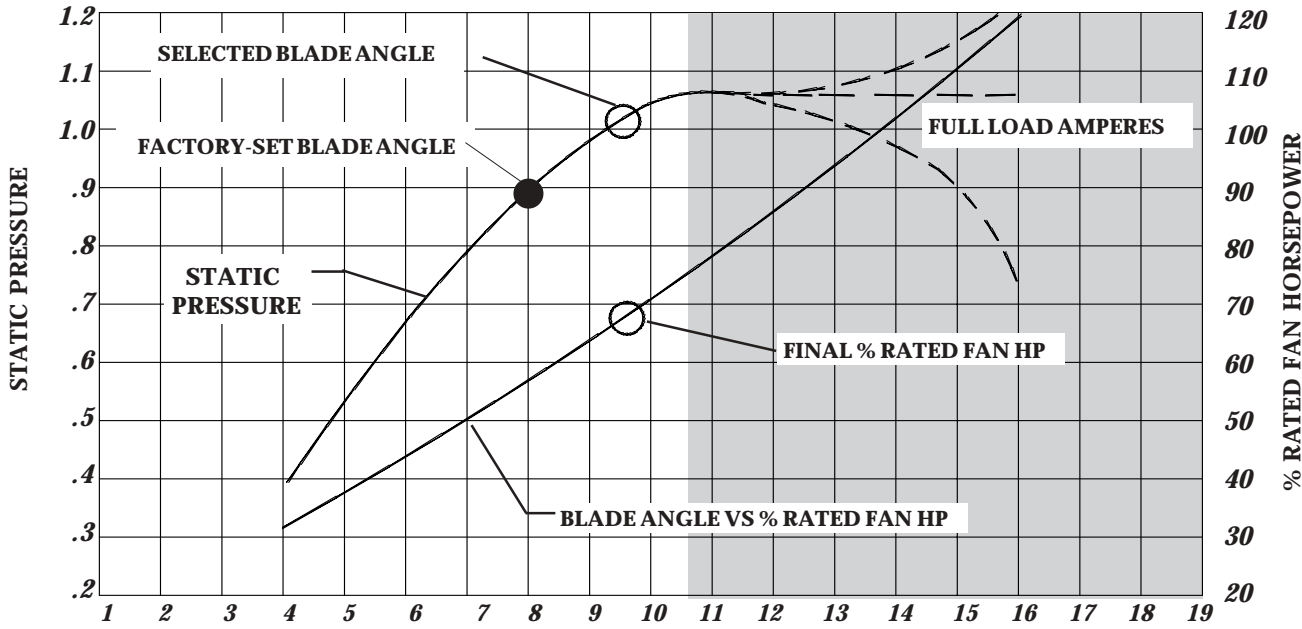

4.4.1 Sample Graph of Blade Angle in Degrees

Note in the chart above that static pressure (and air flow) has reached its maximum at an 11 degree blade setting and blade overload is beginning. With further increase in blade angle, anything may happen, as indicated by the dotted extensions into the shaded overload area. Note that the final selected blade angle is

5% below the point where the static pressure curve becomes level. The horsepower curve has been added to illustrate the point that in an overload condition, horsepower will increase without increased performance.

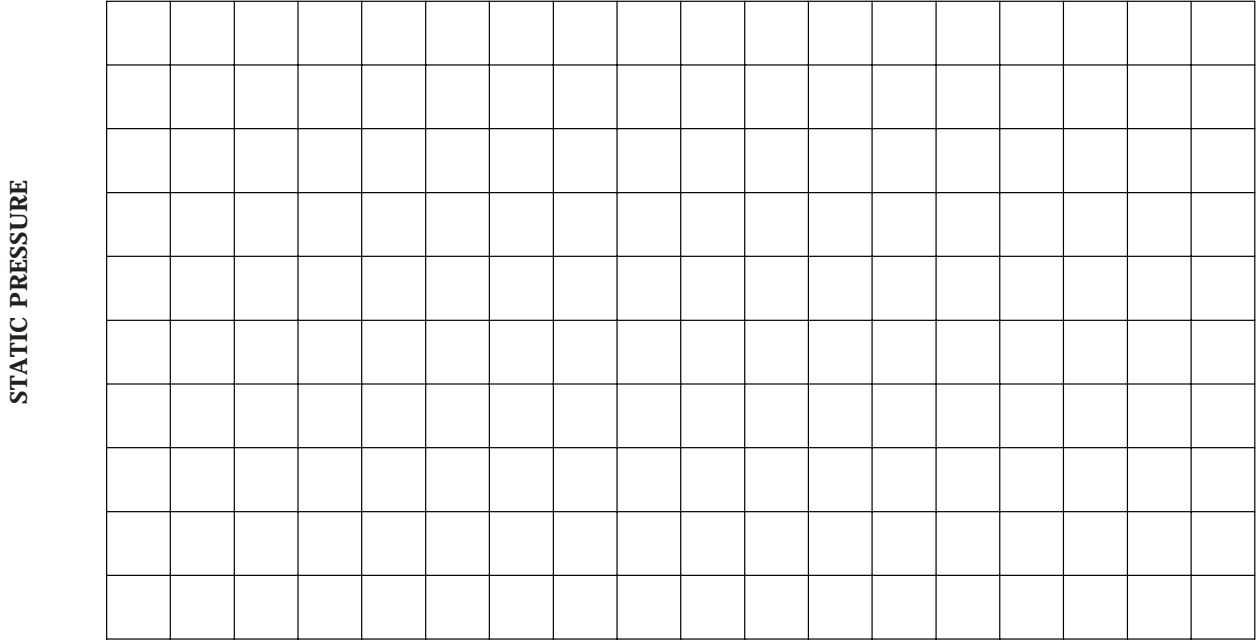

BLANK CHART FOR CUSTOMER USE

4.5 DAMAGING OPERATING CONDITIONS

4.5.1 GENERAL

Any condition which causes repeated blade loading and unloading is detrimental to fan performance, both in terms of efficiency and structural durability. Normal obstructions, of course, must be expected in the air stream. There are certain conditions, however, which may be avoided by reasonable attention to the points briefly discussed in this section. Additional information on the importance of inlet and discharge conditions can be found in Moore's General Catalog.

Ideally, air should approach a fan in an axial direction and at a uniform velocity over the area of the fan. Air approaching a fan at an angle tends to increase the relative velocity of the blades to the air on one side of the fan and decrease the relative velocity on the other side. This means that the fan blade during one-half of its revolution is picking up a heavier air load due to the higher relative velocity and, through the other half of its revolution, a lower air load as it goes "down wind". The net result is a repetitive loading and unloading of the blades at each revolution of the fan. This condition can be quite serious if the velocities are high and the angle of approach deviates considerably from axial.

4.5.2 WIND

With a vertically mounted fan blowing outward into the wind and surrounded by a short fan ring or stack, high winds may cause some concern. The farther the ring extends beyond the fan, the less effect would be expected from wind. It is a fact, however, that wind across the face of the ring will affect the direction of air flow well down into the ring. In the case of a fan installed near the outlet of the ring, the direction from axial of the fan discharge may be increased by as much as 45° under high wind conditions.

In the case of a fan blowing inward in a short ring, the condition is even more critical. In such an installation, the air on the inlet side of the fan has a horizontal velocity which may be quite high. It is necessary for the fan to pick up this air and direct it inward. In a strong wind, the angle of air moving through the fan may be increased more than 45°.

The illustration above assumes a fan operating with a tip speed (V_B) of 10,000 feet per minute (114 miles per

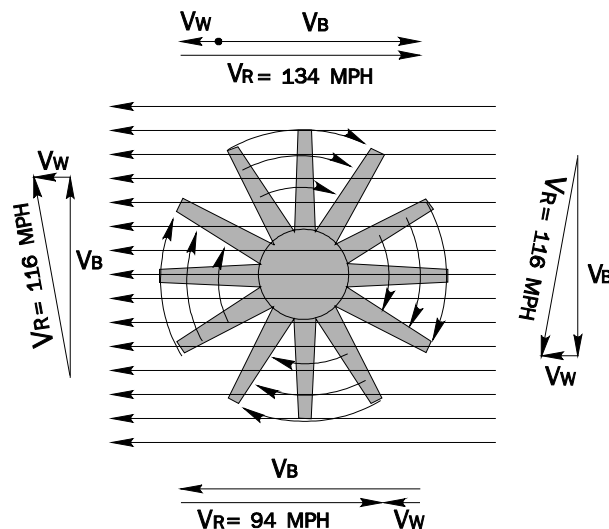

hour) with a horizontal component of wind velocity (V_w) of 20 miles per hour. Note that the velocity (V_R) of the fan blade relative to the air varies by a factor of 1.43. The blade load varies as the square of this velocity, or 2.05.

THE EFFECT OF AIR LOAD ON HUB AND DRIVE

Moore fan blades are attached to the hub by a pivot. As the fan rotates, centrifugal force causes the blades to rise (as do the blades of a helicopter). The air load (F_A) is uniform over the blade, but there is a point (shown on the blade in the drawing below) where, if the total load were applied at that point, the effect would be the same. The resultant of the air load (F_A), assumed in this example to be downward, and the horizontal centrifugal force (F_C) is the force on the blade (F_B). The blade automatically posi-

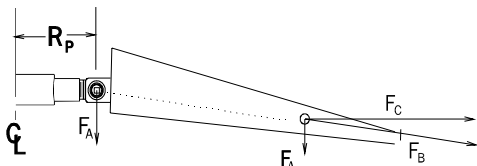

tions itself in the direction of this force with the result that the force is translated inward to the pivot point, as illustrated by the dotted line. The effect of this arrangement is exactly as if the total air load (F_A) were applied at the pivot point rather than at the point outward on the blade. The maximum bending moment applied to the shaft by the air load is equal to the load (F_A) multiplied by the distance from the fan centerline to the pivot point (R_p).

In conventional fans with rigidly attached blades, the bending moment at the shaft due to the air load is equal to the load (F_A) multiplied by the distance from the fan centerline to the point of application of the force on the blade (R_F). This moment will be from 2 to 4 times as great as that produced by the Moore fan under the same condi-

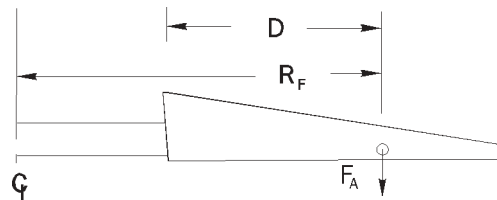

tions.

Also of concern with the conventional fan is the bending moment due to the air load at the point of attachment of the blades to the hub since this is usually the structurally weakest area of the fan. The moment due to the air load at this point is the load (F_A) times the distance (D). For the Moore fan, this moment is zero since the blades are attached at the pivot point.

A more complete discussion of the Moore fan design can be found in The Moore Company's General Catalog.

In this rather common wind condition, then, it can be seen that the blade load on the side where the blade is going against the wind will be double the load on the side where the blade is going with the wind. In a 40 mile per hour wind, the blade load would vary by a factor greater than 4. In a 60 mile per hour wind, the load would vary by a factor of more than 10! It is obvious that operation under such conditions will impose tremendous repetitive loadings on the fan blades.

In areas of unusually high wind velocities, it may be advisable to shield the fan in some manner.

4.5.3 OBSTRUCTIONS

Obstructions of one type or another in the air stream, ahead of or behind the fan, are to be expected. In fact, it would be virtually impossible to eliminate all obstructions. Structural supporting members, foundations and the like, need not be of serious concern although all obstructions, even small ones, will increase the static pressure and must be taken into consideration by the system designer in specifying the fan performance.

The total free area from which the fan can draw air should be twice the net area of the fan (fan area minus hub area). In other words, the air approaching the inlet of the fan should have no more than half the velocity of the air passing through the fan. This area should be distributed reasonably uniformly. It would be unwise to attempt to operate a fan with one-half or one-third of

the fan area completely blanked off. Such a condition would cause stalling of the fan blade through one-half the revolution but create a condition of overload in the half which was not blocked off. Excessive vibration would result. Any condition which forces the air to approach the fan in a non-axial direction should be avoided.

4.5.4 UNEVEN TIP CLEARANCE

Where fan rings are out of round or not centered with the fan, the tip clearance of each blade will vary as it makes a revolution. If tip clearance is tight at one point and excessive at another, proper flow will establish itself at the tight point, loading the blade to the very tip, while at the loose point the air will flow from the high pressure side of the blade through the opening between the blade tip and the ring and nullify the negative pressure on the under side of the blade. This will unload the blade near the tip within the area of excessive tip clearance. Under this condition, the blade will load and unload near the tip one or more times per revolution, resulting in an undesirable repetitive vibration. Every effort should be made to keep the tip clearance to a minimum and to have this clearance as constant as possible around the entire ring.