



Pneumatic Actuator

Durastroke Series 1000 – 1099

Installation & Maintenance Instructions

INSTALLATION

Installation of Airtech Products Durastroke pneumatic actuator is a simple two-step process. Mounting of the actuator / attachment to load and connection of air line(s). Before starting installation, inspect the actuator and contents of the shipping carton to ensure all required parts are present. Check the following:

- Positioner (if ordered) is firmly secured to the top of the actuator?
- Clevis is present at the end of travel stem?
- The following hardware kit was included:
 1. Five (5) 3/8-16 x 1 1/2" long bolts
 2. Four (4) 3/8" lock washers
 3. One (1) 3/8-16 locking nut

A) Mounting The Actuator:

1. The actuator can be mounted in either a vertical or horizontal position.
2. The actuator is supplied with four (4) 3/8"-16 bolt-holes in the bottom plate for attachment to a mounting plate or bracket.
3. A hole at least 13/16" (but not larger than 1" diameter) must be provided in the center of the actuator mounting bolthole pattern for penetration of the actuator travel stem and clevis.
4. Attach the actuator to the mounting bracket with the four supplied 3/8"-16 x 1 1/2" bolts and lock washers. In a rotating pattern, tighten each to 16 Ft-Lbs torque.
5. **DO NOT ATTACH THE ACTUATOR TO THE TORQUE TUBE LEVER ARM YET.**

B) Air Line Connection:

Actuator without Positioner (Series 1000 – 1099):

Since there is no positioner, the actuator is shipped with a cover plate bolted to the top. At the center of that cover plate is a single 1/4" NPT inlet port.

1. Using Teflon thread tape or a suitable compound, install a 1/4" threaded adapter to the inlet port then connect 1/4" or 3/8" air line to adapter. Depending on the load, the actuator stem will start extension at 6 PSI and be completely extended at 30 PSI.
2. Do not exceed 45 PSI inlet pressure to the actuator.

C) Connecting The Linkage:

1. In most cases**, the torque tube lever arm will be preset at the factory to drive the louver either “Fail Open” or “Fail Closed” upon loss of air and / or actuator retraction. As a result, connection of the linkage will be a simple matter of manually situating the louver blades and actuator stem to the correct position and then attaching the control link to the clevis (at the base of the actuator stem) and finally to the torque tube lever arm. To determine how the actuator and louver blades should be positioned, please note the following instructions:
 - a. **“Fail Open” Louvers**
 - Stroke actuator to fully extended and manually set louver to fully closed position before connecting louver lever arm & link to actuator clevis.
 - b. **“Fail Closed” Louvers**
 - Ensure actuator is completely retracted and manually set louvers to fully closed position before connecting louver lever arm & link to actuator clevis.
2. When all sections are installed and connected, stroke the actuator several times to ensure it moves the entire louver freely without binding or interference. On very large louvers with multiple sections, inspect to confirm all the sections are fully open and completely closing in unison. Some adjustment of end links or torque tube clamps may be required to ensure all louver blades open and shut consistently down the entire length or across the entire width of the louver.
3. Check all attachment fasteners to ensure all are properly tightened and completely engaged to the louver flange.
4. If applicable, check all end link connections and torque tube couplers to ensure they are properly tightened and fasteners are completely engaged.

****For new orders only when the actuator is purchased in conjunction w/louvers.** Please contact the factory for specific instructions on retrofit or other applications that did not see both the actuator and louver originate as simultaneous/concurrent Airtech orders

MAINTENANCE

Annual Inspection:

1. Inspect and verify all mechanical connections
 - Actuator bolting to mounting plate or bracket
 - Check mounting plate or bracket rigidity
 - Confirm actuator to mounting bracket bolt tightness
 - Clevis general condition
 - Visually inspect overall clevis condition
 - Confirm fastener between clevis and actuator link is sound
 - Link to torque tube lever arm
 - Visually inspect overall link condition
 - Confirm fastener between link and torque tube lever arm is sound
 - Positioner attachment to actuator body
 - Visually inspect positioner for visible cracks or damage
 - Confirm positioner is securely fastened to actuator body

2. Inspect and verify all pneumatic connections
 - Instrument air
 - Supply line to threaded adapter
 - Adapter to positioner
 - Supply air
 - Supply line to threaded adapter
 - Adapter to positioner
 - Diaphragm
 - Confirm 35-40 psig air at Supply Port
 - § Listen for leaks at stem

Repair Kit & Recommended Spare Parts List

The following items are recommended as a single actuator repair kit. It is suggested that one repair kit be kept on hand for each 3 actuators on site and in service. Please note a repair & maintenance kit is not offered for the positioner because of the complexity of that particular item. Best practice is simply to replace a non-operational positioner. Item numbers noted below refer to Airtech Products, Inc. drawing, "Durastroke 1100 Actuator".

| <u>Item Number</u> | <u>Description</u> |
|---------------------------|---------------------------|
| 2 | Guide Bushing |
| 4 | Snap Ring |
| 9 | Diaphragm |
| 13 | Diaphragm Washer |
| 15 | O-Ring |

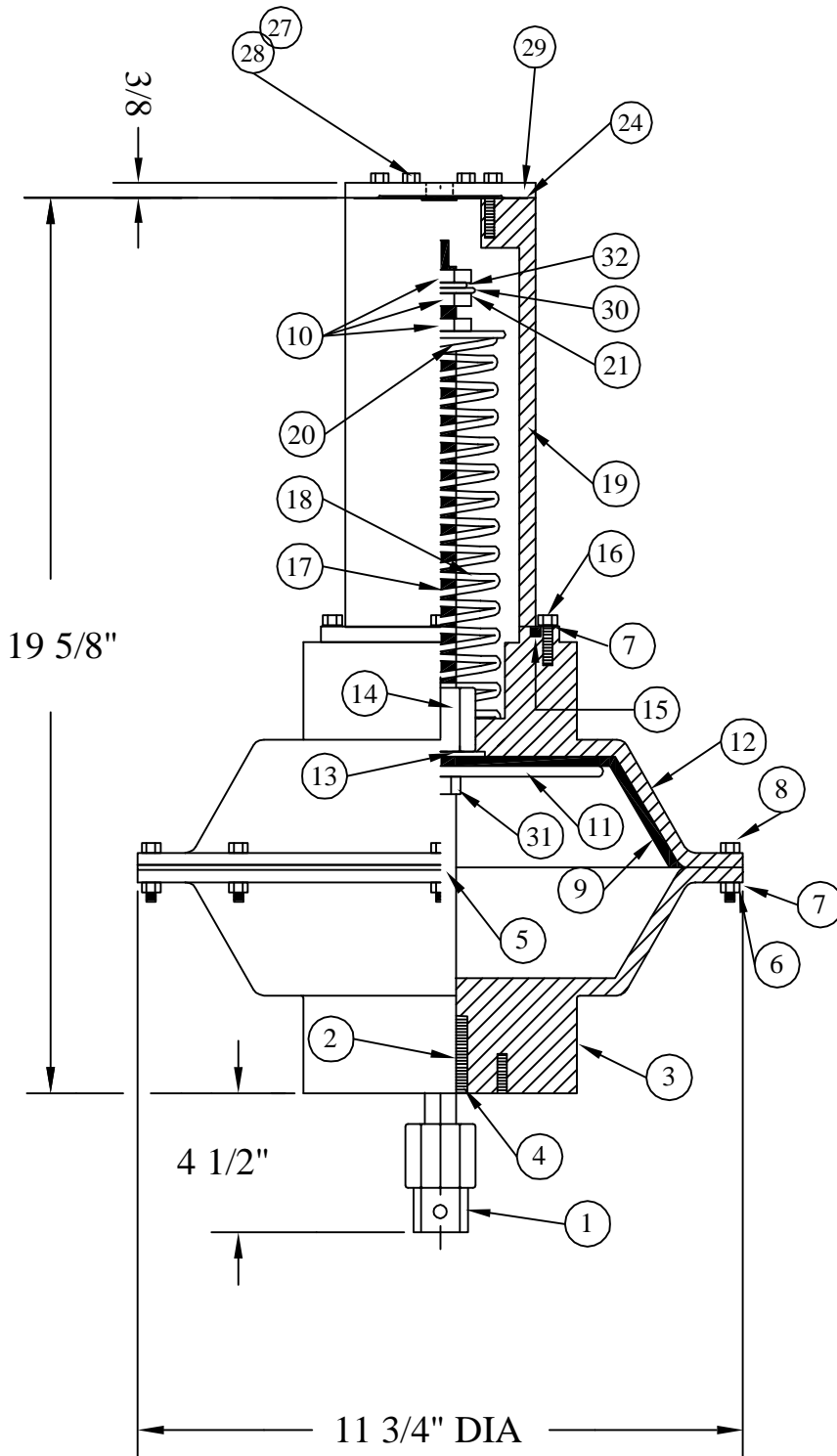

| ITEM | QTY. | DESCRIPTION |
|------|------|--------------------|
| 1 | 1 | CLEVIS |
| 2 | 1 | GUIDE BUSHING |
| 3 | 1 | LOWER HOUSING |
| 4 | 1 | SNAP RING |
| 5 | 1 | STEM |
| 6 | 8 | HOUSING NUT |
| 7 | 12 | LOCKWASHER |
| 8 | 12 | HOUSING SCREW |
| 9 | 1 | DIAPHRAGM |
| 10 | 3 | LOCKNUT |
| 11 | 1 | DIAPHRAGM PLATE |
| 12 | 1 | UPPER HOUSING |
| 13 | 1 | DIAPHRAGM WASHER |
| 14 | 1 | CONNECTOR NUT |
| 15 | 1 | O-RING |
| 16 | 4 | SPRING COVER SCREW |
| 17 | 1 | SPRING ROD |
| 18 | 1 | MAIN SPRING |
| 19 | 1 | SPRING COVER |
| 20 | 1 | SPRING WASHER |
| 21 | 1 | WASHER |
| 22 | | |
| 23 | | |
| 24 | 1 | GASKET |
| 25 | | |
| 26 | | |
| 27 | 6 | LOCKWASHER |
| 28 | 6 | COVER PLATE SCREW |
| 29 | 1 | COVER PLATE |
| 30 | 1 | WASHER |
| 31 | 1 | LOCKNUT |
| 32 | 1 | SAE FLAT WASHER |

AIRTECH PRODUCTS, INC.

Dwg. Name:
DURASTROKE 1000-1099 ACTUATOR

Date:
1/30/08

By:
STEWART

Customer:

File #:
AIR MOTOR

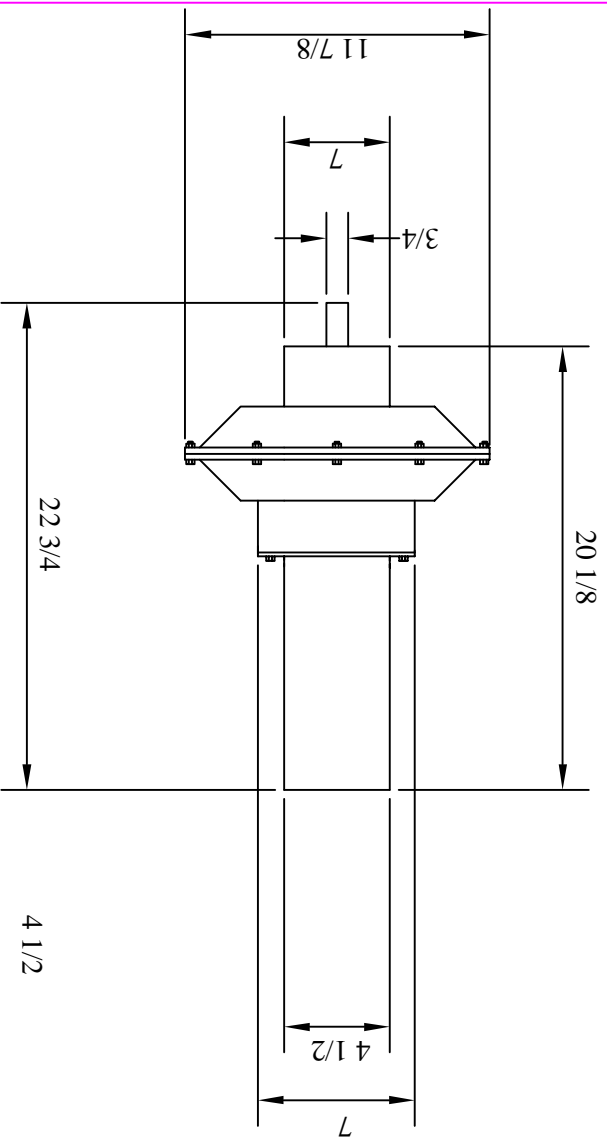

(4) 7/16" DIA. BOLT HOLES
ON 2 7/8" BOLT CIRCLE

Parameter

| | |
|---------------------------|----------------------|
| Housing: | 356-T6 Alum. |
| Travel Stem: | 303 Stainless Steel |
| Includes Clevis: | Yes |
| Clevis Material: | 6061-T6 Aluminum |
| Extending force (45 PSD): | 1384# |
| Retracting force: | |
| Minimum: | 330# |
| Max. (Full Stroke): | 907# |
| Stem Travel: | 3.5" |
| Consumption (Full Stroke) | .5 scfm |
| Weight: | 42 Lbs. |
| Spring | 17-7 Stainless Steel |
| Extreme duty available | Optional |
| Use w/Air or Sour Gas | Optional |
| Lubrication Required | No |

PRESSURE RANGE:

1000 - 1099: 6 - 30 PSIG

| | |
|-------------------------------|---|
| AIRTECH PRODUCTS, INC. | |
| Dwg. Name: | DURASTROKE 1000-1099 DESIGN DETAIL |
| Date: | 1/24/07 |
| By: | Miller |
| Customer: | AIR MOTOR |